

Free of maintenance stop valve with bellows seal - metallic sealing

**ARI-FABA®-Plus -**

**Straight through with flanges**

- DIN DVGW-Type approval (EN-JS1049)
- EN ISO 15848-1 / TA - Luft  
TÜV-Test-No. TA 07 2016 C04
- TRB 801 Annex II No. 45 (except EN-JL1040)

Grey cast iron  
SG iron  
Cast steel  
Forged steel  
Stainless steel

**Fig. 046**

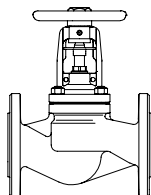

Page 2-4

**ARI-FABA®-Plus -**

**Straight through with butt weld ends**

- EN ISO 15848-1 / TA - Luft  
TÜV-Test-No. TA 07 2016 C04
- TRB 801 Annex II No. 45

Forged steel

**Fig. 040**

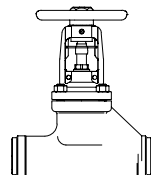

Page 5

**ARI-FABA®-Plus -**

**Straight through with butt weld ends**

- EN ISO 15848-1 / TA - Luft  
TÜV-Test-No. TA 07 2016 C04
- TRB 801 Annex II No. 45

Cast steel

**Fig. 040**

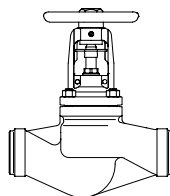

Page 6

**ARI-FABA®-Plus -**

**Y-pattern with flanges**

- EN ISO 15848-1 / TA - Luft  
TÜV-Test-No. TA 07 2016 C04
- TRB 801 Annex II No. 45

Stainless steel

**Fig. 069**

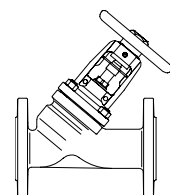

Page 7

**ARI-FABA®-Plus -**

**Y-pattern with butt weld ends**

- EN ISO 15848-1 / TA - Luft  
TÜV-Test-No. TA 07 2016 C04
- TRB 801 Annex II No. 45

Cast steel  
Stainless steel

**Fig. 066**

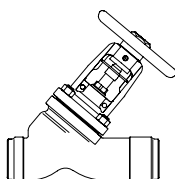

Page 8+9

**ARI-FABA®-Plus -**

**Angle pattern with flanges**

- EN ISO 15848-1 / TA - Luft  
TÜV-Test-No. TA 07 2016 C04
- TRB 801 Annex II No. 45 (except EN-JL1040)

Grey cast iron  
SG iron  
Cast steel

**Fig. 047**

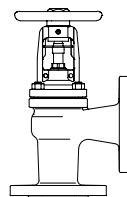

Page 10

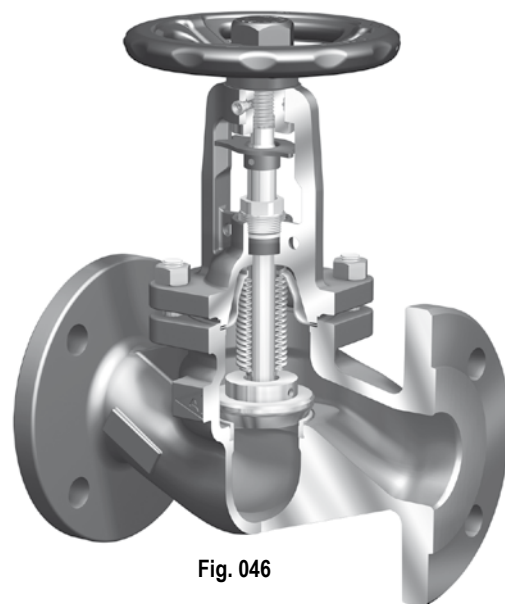

**Fig. 046**

For ANSI versions  
refer to data sheet  
„ARI-FABA®-Plus/-Supra ANSI“

**Features:**

- Double wall bellows seal as standard
- Plug with marginal seat
- Stem with fine thread
- Flat lubricating nipple
- Locking device, countersunk
- Cast iron variations with nodular iron bonnet as standard
- Heat dissipating bonnet
- Bonnet optimised for accessories
- Secondary sealing: gland packing
- Position indicator as standard
- Non-rising handwheel
- Non-rotation lock for each nominal diameter
- External stem thread
- Stem with roll hardened thread

**Stop valve - straight through with flanges and bellows seal (Grey cast iron, SG iron, Cast steel)**

Figure-No.	Nominal pressure	Material	Nominal diameter
12.046	PN16	EN-JL1040	DN15-300
22.046	PN16	EN-JS1049	DN15-350
	Test: • DIN DVGW-Reg. NG-4313AO 0772		
23.046	PN25	EN-JS1049	DN15-150
34.046	PN25	1.0619+N	DN200-400
35.046	PN40	1.0619+N	DN15-250

Test: • EN ISO 15848-1 / TA - Luft TÜV-Test-No. TA 07 2016 C04

Considered standards: • EN 13709 (1.0619+N)  
• EN 13789 (EN-JL1040, EN-JS1049)

Plug design: • Plug with marginal seat standard

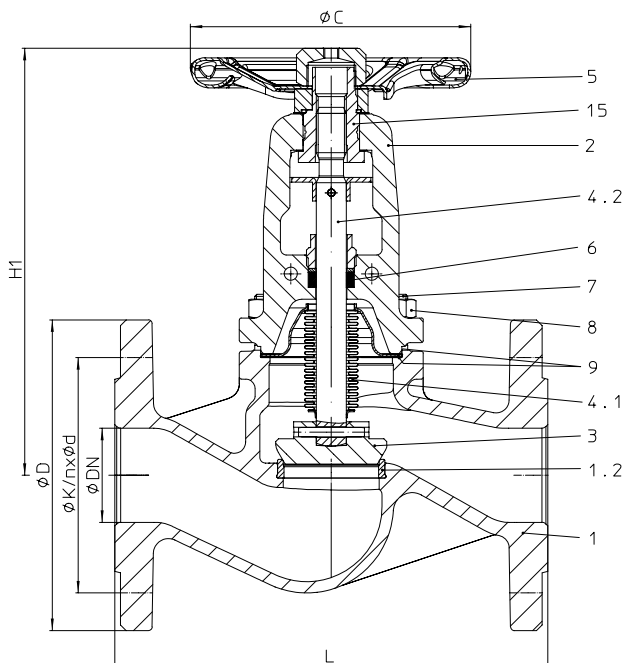
**At high differential pressures a balancing plug is necessary!** (refer to page 12)

Parts					
Pos.	Sp.p.	Description	Fig. 12.046	Fig. 22. / 23.046	Fig. 34. / 35.046
1		Body	EN-JL1040, EN-GJL-250	EN-JS1049, EN-GJS-400-18U-LT	GP240GH+N, 1.0619+N
1.2		Seat ring	X20Cr13+QT, 1.4021+QT		≤DN50: X20Cr13+QT, 1.4021+QT / ≥DN65: G19 9 NbSi, 1.4551
2		Bonnet	EN-JS1049, EN-GJS-400-18U-LT		GP240GH+N, 1.0619+N
3	x	Plug	≤ DN200: X20Cr13+QT, 1.4021+QT (hardened) / ≥ DN250: P265GH, 1.0425 / Stellite 21		
4		Spindle unit	--		
4.1	x	Bellows seal	X6CrNiMoTi17 12 2, 1.4571		
4.2		Stem	X20Cr13+QT, 1.4021+QT		
5		Handwheel	≤DN125: St (cataphoretic coating) / ≥DN150: EN-JL1040, EN-GJL-250 (epoxy-coating)		
6	x	Packing ring	Pure graphite		
7		Hexagon bolt	5.6	--	
7		Stud	--	25CrMo4, 1.7218	
8		Hexagon nut	--	C35E, 1.1181	
9	x	Gasket	Pure graphite (CrNi laminated with graphite)		
15	x	Insert nuts	11SMn30+C, 1.0715+C		
L Spare parts					

DN	15	20	25	32	40	50	65	80	100	125	150	200	250	300	350	400
----	----	----	----	----	----	----	----	----	-----	-----	-----	-----	-----	-----	-----	-----

Face-to-face dimension FTF series 1 acc. to DIN EN 558																	
L	(mm)	130	150	160	180	200	230	290	310	350	400	480	600	730	850	980	1100

Dimensions		Standard-flange dimensions refer to page 14															
H1	(mm)	205	205	210	210	225	230	245	265	365	395	430	550	720	775	975	1015
ØC	PN16 (mm)	125	125	125	125	150	150	175	175	225	300	400	520	520	520	640	640
	PN25 (mm)	125	125	125	125	150	150	175	175	300	300	400	520	520	520	640	640
	PN40 (mm)	125	125	125	125	150	150	175	225	300	300	400	520	520	--	--	--
Travel	(mm)	6	6	8	8	13	13	16	20	25	32	40	50	70	80	90	100
Kvs-value	(m³/h)	5,3	7,2	12	16	28,5	43	75	105	170	270	405	675	1090	1460	2010	2640
Zeta-value	--	2,9	4,9	4,3	6,5	5	5,4	5,1	5,9	5,5	5,3	4,9	5,6	5,2	6,1	5,9	5,9

Weights																	
12. / 22. / 23.046	(kg)	3,7	4,5	5,6	6,9	8,9	11	15,3	21,1	32,4	51,6	74	147	247	404	524	--
34.046	(kg)	--	--	--	--	--	--	--	--	--	--	--	168	268	395	629	865
35.046	(kg)	4,1	5,1	6,2	7,3	10,6	12,6	19,1	26,1	35	60,3	88	160	310	--	--	--

Information / restriction of technical rules need to be observed!

Operating and installation instructions can be downloaded at [www.ari-armaturen.com](http://www.ari-armaturen.com).

ARI-Valves of EN-JL1040 are not allowed to be operated in systems acc. to TRD 110.

A production allowance acc. to TRB 801 No. 45 exists (acc. to TRB 801 No. 45 EN-JL1040 is not allowed.)

The engineer, designing a system or a plant, is responsible for the selection of the correct valve.

Resistance and fitness must be verified (contact manufacturer for information, refer to Product overview and Resistance list).

**Stop valve - straight through with flanges and bellows seal (Stainless steel)**

Figure-No.	Nominal pressure	Material	Nominal diameter
52.046	PN16	1.4408	DN15-250
62.046	PN16	1.4408 Body / 1.0619+N Cover	DN15-250
54.046	PN25	1.4408	DN200-250
64.046	PN25	1.4408 Body / 1.0619+N Cover	DN200-250
55.046	PN40	1.4408	DN15-150
65.046	PN40	1.4408 Body / 1.0619+N Cover	DN15-150

Test: • EN ISO 15848-1 / TA - Luft TÜV-Test-No. TA 07 2016 C04

Considered standards: • EN 13709 (1.0619+N, 1.4408)

Plug design: • Plug with marginal seat standard

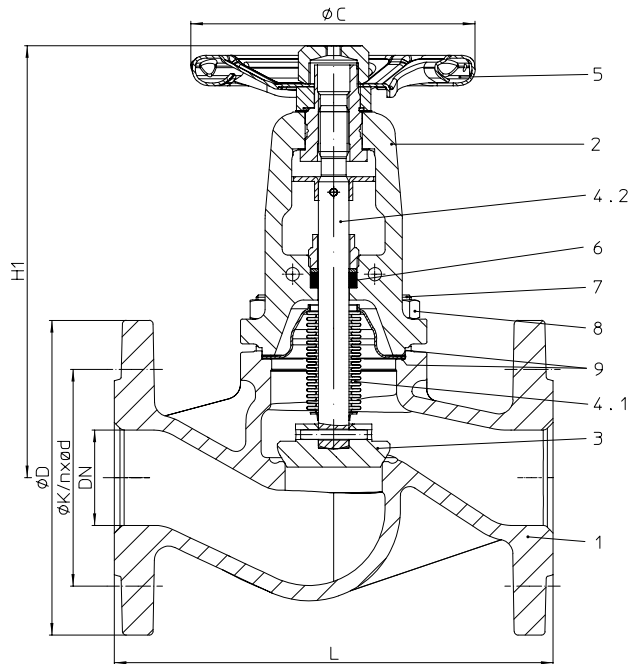
**At high differential pressures a balancing plug is necessary!** (refer to page 12)

Parts				Fig. 52. / 54. / 55.046	Fig. 62. / 64. / 65.046
1		Body	GX5CrNiMo19-11-2, 1.4408		
2		Bonnet	GX5CrNiMo19-11-2, 1.4408		
3	x	Plug	X6CrNiMoTi17 12 2, 1.4571		
4		Spindle unit	--		
4.1	x	Bellows seal	X6CrNiMoTi17 12 2, 1.4571		
4.2		Stem	X6CrNiMoTi17 12 2, 1.4571		
5	x	Handwheel	≤DN125: St (cataphoretic coating) / ≥DN150: EN-JL1040, EN-GJL-250 (epoxy-coating)		
6		Packing ring	Pure graphite		
7		Hexagon bolt	--		
7		Stud	A4-70		
8		Hexagon nut	A4		
9	x	Gasket	Pure graphite (CrNi laminated with graphite)		
L Spare parts					

DN	15	20	25	32	40	50	65	80	100	125	150	200	250
----	----	----	----	----	----	----	----	----	-----	-----	-----	-----	-----

Face-to-face dimension FTF series 1 acc. to DIN EN 558														
L	(mm)	130	150	160	180	200	230	290	310	350	400	480	600	730

Dimensions		Standard-flange dimensions refer to page 14												
H1	(mm)	200	200	210	210	225	230	245	265	365	395	430	550	720
ØC	PN16 (mm)	125	125	125	125	150	150	175	175	225	300	400	520	520
	PN25 (mm)	125	125	125	125	150	150	175	175	300	300	400	520	520
	PN40 (mm)	125	125	125	125	150	150	175	225	300	300	400	520	520
Travel	(mm)	6	6	8	8	13	13	16	20	25	32	40	50	70
Kvs-value	(m³/h)	5,3	7,2	12	16	28,5	43	75	105	170	270	405	675	1090
Zeta-value	--	2,9	4,9	4,3	6,5	5	5,4	5,1	5,9	5,5	5,3	4,9	5,6	5,2
Zeta-value ... range of tolerance for Kvs-values acc. to VDI/VDE 2173														

Weights														
52. / 54. / 62. / 55. / 64. / 65.046	(kg)	4,3	4,8	6,3	7,3	10,3	12,6	19	25	33	53	71	187	272

Information / restriction of technical rules need to be observed!

Operating and installation instructions can be downloaded at [www.ari-armaturen.com](http://www.ari-armaturen.com).

A production allowance acc. to TRB 801 No. 45 exists

The engineer, designing a system or a plant, is responsible for the selection of the correct valve.

Resistance and fitness must be verified (contact manufacturer for information, refer to Product overview and Resistance list).

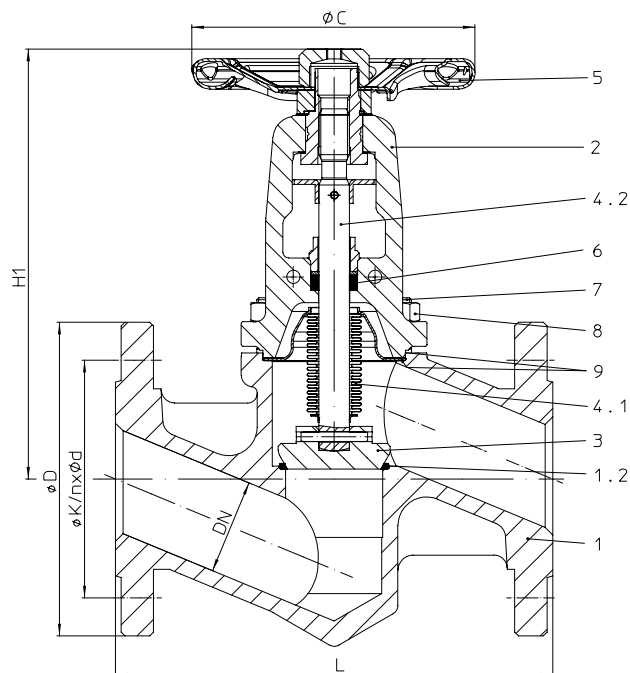
**Stop valve - straight through with flanges and bellows seal (Forged steel)**

DN40-50

Figure-No.	Nominal pressure	Material	Nominal diameter
45.046	PN40	1.0460	DN15-50
	DN >50 refer to Fig. 35.046 (1.0619+N)		

Test:	• EN ISO 15848-1 / TA - Luft TÜV-Test-No. TA 07 2016 C04
-------	--

Considered standards:	• EN 13709 (1.0460)
-----------------------	---------------------

Plug design:	• Plug with marginal seat standard
--------------	------------------------------------

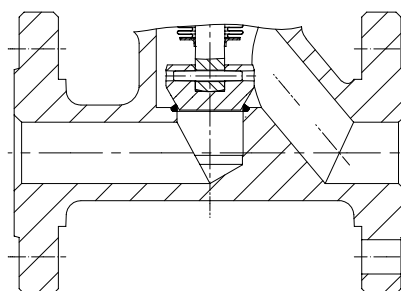

DN15-32

Parts			
Pos.	Sp.p.	Description	Fig. 45.046
1		Body	P250 GH, 1.0460
1.2		Seat	G19 9 NbSi, 1.4551
2		Bonnet	GP240GH+N, 1.0619+N
3	x	Plug	X20Cr13+QT, 1.4021+QT (hardened)
4		Spindle unit	
4.1	x	Bellows seal	X6CrNiMoTi17 12 2, 1.4571
4.2		Stem	X20Cr13+QT, 1.4021+QT
5	x	Handwheel	Fe P01, 1.0330 (cataphoretic coating)
6		Packing ring	Pure graphite
7		Stud	25CrMo4, 1.7218
8		Hexagon nut	C35E, 1.1181
9	x	Gasket	Pure graphite (CrNi laminated with graphite)
L Spare parts			

DN	15	20	25	32	40	50
----	----	----	----	----	----	----

Face-to-face dimension FTF series 1 acc. to DIN EN 558							
L	(mm)	130	150	160	180	200	230

Dimensions		Standard-flange dimensions refer to page 14					
H1	(mm)	215	215	225	230	230	230
ØC (PN40)	(mm)	125	125	125	125	150	150
Travel	(mm)	6	6	8	8	13	13
Kvs-value	(m³/h)	3,6	6,3	10	13	24	36
Zeta-value	--	6,2	6,4	6,2	9,9	7,1	7,7

Zeta-value ... range of tolerance for Kvs-values acc. to VDI/VDE 2173

Weights							
45.046	(kg)	3,8	4,8	5,5	7	10	12

Information / restriction of technical rules need to be observed!

 Operating and installation instructions can be downloaded at [www.ari-armaturen.com](http://www.ari-armaturen.com).

A production allowance acc. to TRB 801 No. 45 exists.

The engineer, designing a system or a plant, is responsible for the selection of the correct valve.

Resistance and fitness must be verified (contact manufacturer for information, refer to Product overview and Resistance list).

**Stop valve - straight through with butt weld ends and bellows seal (Forged steel)**

Figure-No.	Nominal pressure	Material	Nominal diameter
45.040	PN40	1.0460	DN15-50
	DN >50 refer to Fig. 35.040 (1.0619+N)		

Butt weld ends according to DIN EN 12627 - 4 (refer to page 11)

Test: • EN ISO 15848-1 / TA - Luft TÜV-Test-No. TA 07 2016 C04

Considered standards: • EN 13709 (1.0460)

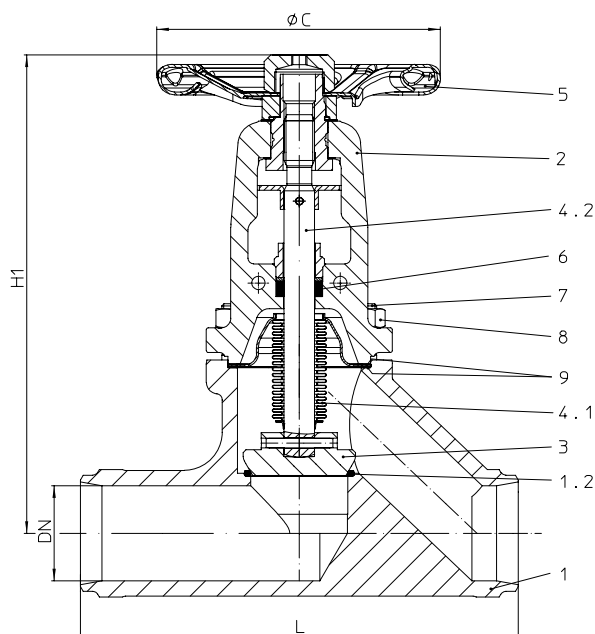
Plug design: • Plug with marginal seat standard

Parts			
Pos.	Sp.p.	Description	Fig. 45.040
1		Body	P250 GH, 1.0460
1.2		Seat	G19 9 NbSi, 1.4551
2		Bonnet	GP240GH+N, 1.0619+N
3	x	Plug	X20Cr13+QT, 1.4021+QT (hardened)
4		Spindle unit	
4.1	x	Bellows seal	X6CrNiMoTi17 12 2, 1.4571
4.2		Stem	X20Cr13+QT, 1.4021+QT
5	x	Handwheel	Fe P01, 1.0330 (cataphoretic coating)
6		Packing ring	Pure graphite
7		Stud	25CrMo4, 1.7218
8		Hexagon nut	C35E, 1.1181
9	x	Gasket	Pure graphite (CrNi laminated with graphite)
L Spare parts			

DN	15	20	25	32	40	50
----	----	----	----	----	----	----

Face-to-face dimension ETE series 1 according to DIN EN 12982							
L	(mm)	130	150	160	180	200	230

Dimensions		Butt weld ends according to DIN EN 12627 - 4 (refer to page 11)					
H1	(mm)	215	215	225	230	250	255
ØC (PN40)	(mm)	125	125	125	125	150	150
Travel	(mm)	6	6	8	8	13	13
Kvs-value	(m³/h)	3,6	3,6	10	13	21	32
Zeta-value	--	6,2	6,4	6,2	9,9	9,3	9,7
Zeta-value ... range of tolerance for Kvs-values acc. to VDI/VDE 2173							

Weights							
45.040	(kg)	2,6	2,8	3,8	4,2	5,8	8,2

Information / restriction of technical rules need to be observed!

Operating and installation instructions can be downloaded at [www.ari-armaturen.com](http://www.ari-armaturen.com).

A production allowance acc. to TRB 801 No. 45 exists

The engineer, designing a system or a plant, is responsible for the selection of the correct valve.

Resistance and fitness must be verified (contact manufacturer for information, refer to Product overview and Resistance list).

**Stop valve - straight through with butt weld ends and bellows seal (Cast steel)**

Figure-No.	Nominal pressure	Material	Nominal diameter
34.040	PN25	1.0619+N	DN200-300
35.040	PN40	1.0619+N	DN65-250

Butt weld ends according to DIN EN 12627 - 4 (refer to page 11)  
alternative: DN 65-200 with shoed ends of P235GH

Test: • EN ISO 15848-1 / TA - Luft TÜV-Test-No. TA 07 2016 C04

Considered standards: • EN 13709 (1.0619+N)

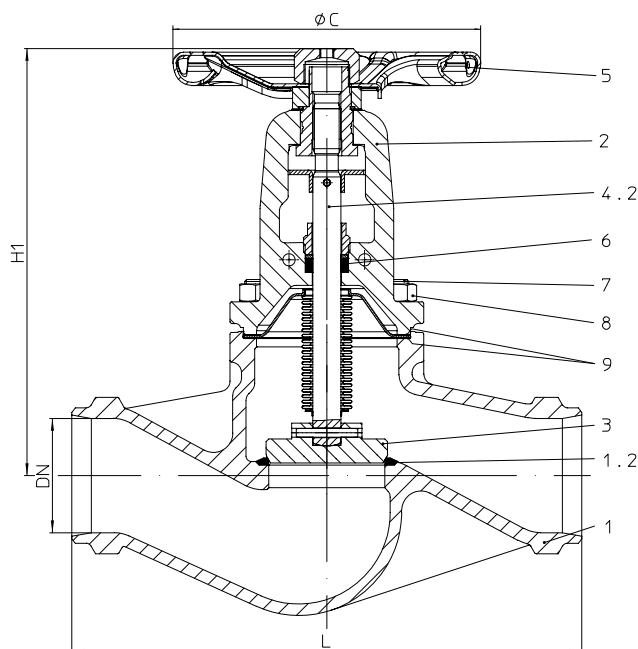
Plug design: • Plug with marginal seat standard

**At high differential pressures a balancing plug is necessary!** (refer to page 12)



Parts			
Pos.	Sp.p.	Description	Fig. 34.040 / 35.040
1		Body	GP240GH+N, 1.0619+N
1.2		Seat	G19 9 NbSi, 1.4551
2		Bonnet	GP240GH+N, 1.0619+N
3	x	Plug	≤DN200: X20Cr13+QT, 1.4021+QT (hardened) / ≥DN250: P265GH, 1.0425 / Stellite 21
4		Spindle unit	
4.1	x	Bellows seal	X6CrNiMoTi17 12 2, 1.4571
4.2		Stem	X20Cr13+QT, 1.4021+QT
5	x	Handwheel	≤DN125: St (cataphoretic coating) / >DN125: EN-JL1040, EN-GJL-250 (epoxy-coating)
6		Packing ring	Pure graphite
7		Stud	25CrMo4, 1.7218
8		Hexagon nut	C35E, 1.1181
9	x	Gasket	Pure graphite (CrNi laminated with graphite)
L Spare parts			

DN	65	80	100	125	150	200	250	300
----	----	----	-----	-----	-----	-----	-----	-----

**Face-to-face dimension ETE series 1 according to DIN EN 12982**

L (mm)	290	310	350	400	480	600	730	850
--------	-----	-----	-----	-----	-----	-----	-----	-----

**Dimensions** Butt weld ends according to DIN EN 12627 - 4 (refer to page 11)

H1 (mm)	245	265	365	395	430	550	720	775
ØC	PN25 (mm)	--	--	--	--	520	520	520
	PN40 (mm)	175	225	300	300	400	520	--
Travel (mm)	16	20	25	32	40	50	70	80
Kvs-value (m³/h)	75	105	170	270	405	675	1090	1460
Zeta-value	--	5,1	5,9	5,5	5,3	4,9	5,6	5,2

Zeta-value ... range of tolerance for Kvs-values acc. to VDI/VDE 2173

**Weights**

Figure-No.	(kg)	12	16,8	23,6	40	56	160	242	370
34.040	(kg)	--	--	--	--	--	160	242	370
35.040	(kg)	12	16,8	23,6	40	56	166	251	--

Information / restriction of technical rules need to be observed!

Operating and installation instructions can be downloaded at [www.ari-armaturen.com](http://www.ari-armaturen.com).

A production allowance acc. to TRB 801 No. 45 exists

The engineer, designing a system or a plant, is responsible for the selection of the correct valve.

Resistance and fitness must be verified (contact manufacturer for information, refer to Product overview and Resistance list).

**Stop valve - Y-pattern with flanges and bellows seal (Stainless steel)**

Figure-No.	Nominal pressure	Material	Nominal diameter
52.069	PN16	1.4408	DN15-200
62.069	PN16	1.4408 Body / 1.0619+N Cover	DN15-200
54.069	PN25	1.4408	DN200
64.069	PN25	1.4408 Body / 1.0619+N Cover	DN200
55.069	PN40	1.4408	DN15-150
65.069	PN40	1.4408 Body / 1.0619+N Cover	DN15-150

Test: • EN ISO 15848-1 / TA - Luft TÜV-Test-No. TA 07 2016 C04

Considered standards: • EN 13709 (1.0619+N, 1.4408)

Plug design: • Plug with marginal seat standard

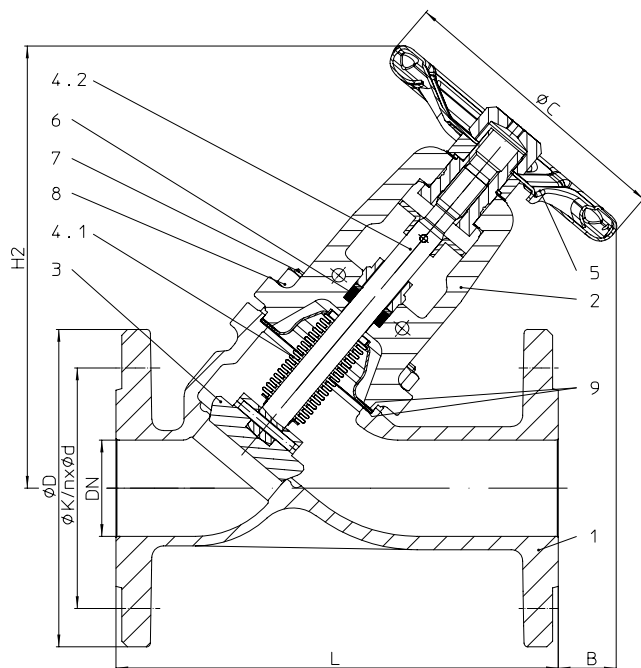
**At high differential pressures a balancing plug is necessary!** (refer to page 12)

Parts			
Pos.	Sp.p.	Description	Fig. 52.069 / Fig. 54.069 / Fig. 55.069
1		Body	GX5CrNiMo19-11-2, 1.4408
2		Bonnet	GX5CrNiMo19-11-2, 1.4408
3	x	Plug	X6CrNiMoTi17 12 2, 1.4571
4		Spindle unit	
4.1	x	Bellows seal	X6CrNiMoTi17 12 2, 1.4571
4.2		Stem	X6CrNiMoTi17 12 2, 1.4571
5	x	Handwheel	≤DN125: St (cataphoretic coating) / ≥DN150: EN-JL1040, EN-GJL-250 (epoxy-coating)
6		Packing ring	Pure graphite
7		Stud	A4-70
8		Hexagon nut	A4
9	x	Gasket	Pure graphite (CrNi laminated with graphite)
L Spare parts			

DN	15	20	25	32	40	50	65	80	100	125	150	200
----	----	----	----	----	----	----	----	----	-----	-----	-----	-----

Face-to-face dimension FTF series 1 acc. to DIN EN 558												
L	(mm)	130	150	160	180	200	230	290	310	350	400	600

Dimensions		Standard-flange dimensions refer to page 14											
H2	(mm)	195	195	205	205	235	235	265	295	380	415	480	615
ØC	PN16 (mm)	125	125	125	125	150	150	175	175	225	300	400	520
	PN25 (mm)	125	125	125	125	150	150	175	175	300	300	400	520
	PN40 (mm)	125	125	125	125	150	150	175	225	300	300	400	520
B	(mm)	95	70	70	55	65	35	15	50	120	100	90	140
Travel	(mm)	6	6	8	8	13	13	16	20	25	32	40	50
Kvs-value	(m³/h)	6,4	9,5	14,5	19,5	36	54	92	127	205	324	485	810
Zeta-value	--	2	2,8	3	4,4	3,2	3,4	3,4	4,1	3,8	3,7	3,4	3,9

Zeta-value ... range of tolerance for Kvs-values acc. to VDI/VDE 2173

Weights													
52. / 54. / 62.069	(kg)	4	4,5	5,4	6,5	8,5	11,7	16	21,7	31,1	43,5	62	180
55. / 64. / 65.069	(kg)	4	4,5	5,4	6,5	8,5	11,7	16	21,7	31,1	43,5	62	186

Information / restriction of technical rules need to be observed!

Operating and installation instructions can be downloaded at [www.ari-armaturen.com](http://www.ari-armaturen.com).

A production allowance acc. to TRB 801 No. 45 exists

The engineer, designing a system or a plant, is responsible for the selection of the correct valve.

Resistance and fitness must be verified (contact manufacturer for information, refer to Product overview and Resistance list).



**Stop valve - Y-pattern with butt weld ends and bellows seal (Cast steel)**

Figure-No.	Nominal pressure	Material	Nominal diameter
34.066	PN25	1.0619+N	DN200-300
35.066	PN40	1.0619+N	DN15-250

Butt weld ends according to DIN EN 12627 - 4 (refer to page 11)

Test: • EN ISO 15848-1 / TA - Luft TÜV-Test-No. TA 07 2016 C04

Considered standards: • EN 13709 (1.0619+N)

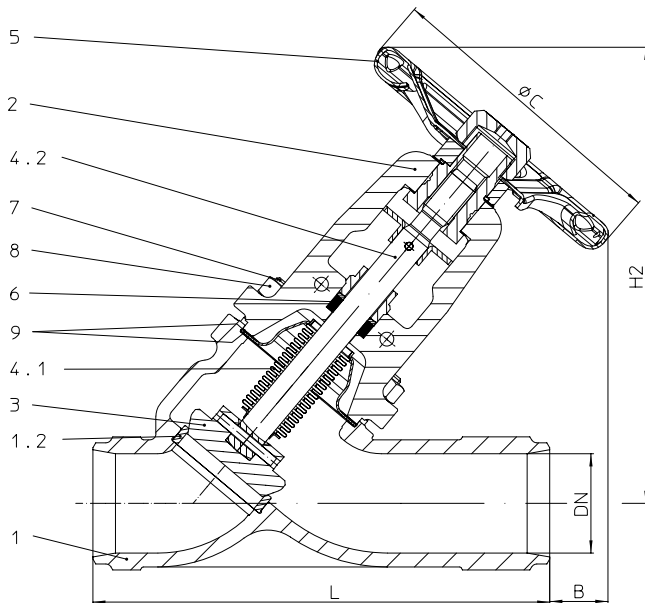
Plug design: • Plug with marginal seat standard

**At high differential pressures a balancing plug is necessary!** (refer to page 12)

Parts			
Pos.	Sp.p.	Description	Fig. 34./35.066
1		Body	GP240GH+N, 1.0619+N
1.2		Seat ring	≤DN80: X20Cr13+QT, 1.4021+QT / >DN80: G19 9 NbSi, 1.4551
2		Bonnet	GP240GH+N, 1.0619+N
3	x	Plug	≤DN200: X20Cr13+QT, 1.4021+QT (hardened) / ≥DN250: P265GH, 1.0425 / Stellite 21
4		Spindle unit	
4.1	x	Bellows seal	X6CrNiMoTi17 12 2, 1.4571
4.2		Stem	X20Cr13+QT, 1.4021+QT
5	x	Handwheel	≤DN125: St (cataphoretic coating) / >DN125: EN-JL1040, EN-GJL-250 (epoxy-coating)
6		Packing ring	Pure graphite
7		Stud	25CrMo4, 1.7218
8		Hexagon nut	C35E, 1.1181
9	x	Gasket	Pure graphite (CrNi laminated with graphite)
L Spare parts			

DN	15	20	25	32	40	50	65	80	100	125	150	200	250	300
----	----	----	----	----	----	----	----	----	-----	-----	-----	-----	-----	-----

Face-to-face dimension ETE series 1 according to DIN EN 12982															
L	(mm)	130	150	160	180	200	230	290	310	350	400	480	600	730	850

Dimensions		Butt weld ends according to DIN EN 12627 - 4 (refer to page 11)													
H2	(mm)	195	195	205	205	235	235	265	295	380	415	480	615	740	795
B	(mm)	85	65	65	50	60	35	10	45	90	60	50	110	100	45
ØC	PN25	(mm)	--	--	--	--	--	--	--	--	--	--	520	520	520
	PN40	(mm)	125	125	125	125	150	150	175	225	300	300	400	520	520
Travel	(mm)	6	6	8	8	13	13	16	20	25	32	40	50	70	80
Kvs-value	(m³/h)	6,4	9,5	14,5	19,5	36	54	92	127	205	324	485	810	1310	1752
Zeta-value	--	2	2,8	3	4,4	3,2	3,4	3,4	4,1	3,8	3,7	3,4	3,9	3,6	4,2
Zeta-value ... range of tolerance for Kvs-values acc. to VDI/VDE 2173															

Weights															
34.066	(kg)	--	--	--	--	--	--	--	--	--	--	--	138	230	317
35.066	(kg)	2,8	3	3,4	3,6	4,5	7,3	9	11,4	30	42	62	144	239	--

Information / restriction of technical rules need to be observed!

 Operating and installation instructions can be downloaded at [www.ari-armaturen.com](http://www.ari-armaturen.com).

A production allowance acc. to TRB 801 No. 45 exists

The engineer, designing a system or a plant, is responsible for the selection of the correct valve.

Resistance and fitness must be verified (contact manufacturer for information, refer to Product overview and Resistance list).



**Stop valve - Y-pattern with butt weld ends and bellows seal (Stainless steel)**

Figure-No.	Nominal pressure	Material	Nominal diameter
54.066	PN25	1.4581	DN200
55.066	PN40	1.4581	DN15-150

Butt weld ends according to DIN EN 12627 - 4 (refer to page 11)

Test: • EN ISO 15848-1 / TA - Luft TÜV-Test-No. TA 07 2016 C04

Considered standards: • EN 13709 (1.4581)

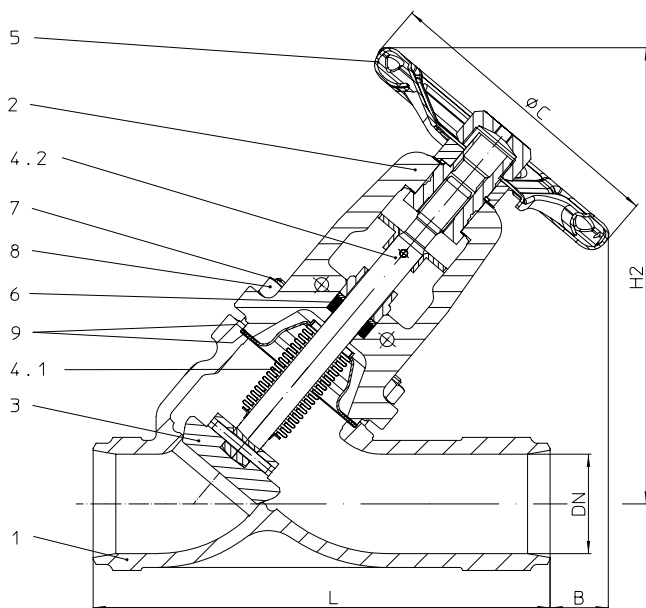
Plug design: • Plug with marginal seat standard

**At high differential pressures a balancing plug is necessary!** (refer to page 12)

Parts			
Pos.	Sp.p.	Description	Fig. 54./55.066
1		Body	GX5CrNiMoN19-11-2, 1.4581
2		Bonnet	GX5CrNiMo19-11-2, 1.4408
3	x	Plug	X6CrNiMoTi17 12 2, 1.4571
4		Spindle unit	
4.1	x	Bellows seal	X6CrNiMoTi17 12 2, 1.4571
4.2		Stem	X6CrNiMoTi17 12 2, 1.4571
5	x	Handwheel	≤DN125: St (cataphoretic coating) / >DN125: EN-JL1040, EN-GJL-250 (epoxy-coating)
6		Packing ring	Pure graphite
7		Stud	A2-70
8		Hexagon nut	A2
9	x	Gasket	Pure graphite (CrNi laminated with graphite)
L Spare parts			

DN	15	20	25	32	40	50	65	80	100	125	150	200
----	----	----	----	----	----	----	----	----	-----	-----	-----	-----

Face-to-face dimension ETE series 1 according to DIN EN 12982													
L	(mm)	130	150	160	180	200	230	290	310	350	400	480	600

Dimensions		Butt weld ends according to DIN EN 12627 - 4 (refer to page 11)											
H2	(mm)	195	195	205	205	235	235	265	295	380	415	480	615
B	(mm)	85	65	65	50	60	35	10	45	90	60	50	110
ØC	PN25 (mm)	--	--	--	--	--	--	--	--	--	--	--	520
	PN40 (mm)	125	125	125	125	150	150	175	225	300	300	400	520
Travel	(mm)	6	6	8	8	13	13	16	20	25	32	40	50
Kvs-value	(m³/h)	6,4	9,5	14,5	19,5	36	54	92	127	205	324	485	810
Zeta-value	--	2	2,8	3	4,4	3,2	3,4	3,4	4,1	3,8	3,7	3,4	3,9

Zeta-value ... range of tolerance for Kvs-values acc. to VDI/VDE 2173

Weights													
54.066	(kg)	--	--	--	--	--	--	--	--	--	--	--	157
55.066	(kg)	3,2	3,6	4	4,8	6,8	8,5	10	13,8	32	45	66	157

Information / restriction of technical rules need to be observed!

 Operating and installation instructions can be downloaded at [www.ari-armaturen.com](http://www.ari-armaturen.com).

A production allowance acc. to TRB 801 No. 45 exists

The engineer, designing a system or a plant, is responsible for the selection of the correct valve.

Resistance and fitness must be verified (contact manufacturer for information, refer to Product overview and Resistance list).

## Stop valve - angle pattern with flanges and bellows seal (Grey cast iron, SG iron, Cast steel)

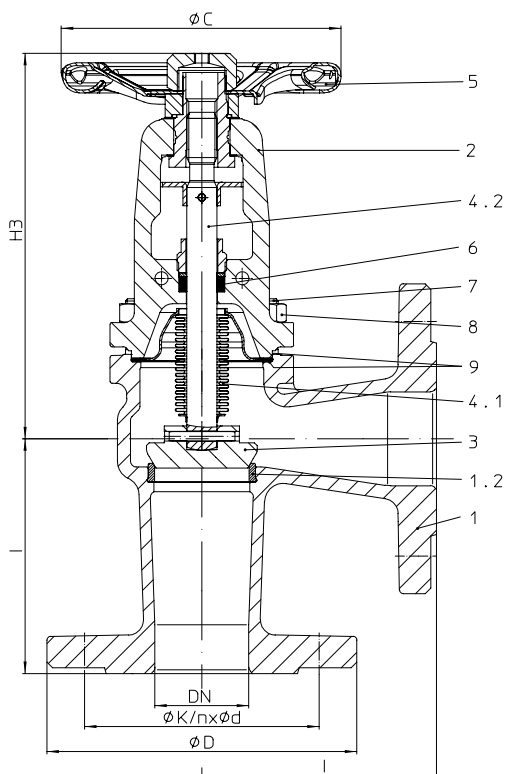

Figure-No.	Nominal pressure	Material	Nominal diameter
12.047	PN16	EN-JL1040	DN15-300
22.047	PN16	EN-JS1049	DN15-300
34.047	PN25	1.0619+N	DN200-300
35.047	PN40	1.0619+N	DN15-150

Test: • EN ISO 15848-1 / TA - Luft TÜV-Test-No. TA 07 2016 C04

Considered standards: • EN 13709 (1.0619+N)  
• EN 13789 (EN-JL1040, EN-JS1049)

Plug design: • Plug with marginal seat standard

**At high differential pressures a balancing plug is necessary!** (refer to page 12)

Parts					
Pos.	Sp.p.	Description	Fig. 12.047	Fig. 22.047	Fig. 34.047 / Fig. 35.047
1		Body	EN-JL1040, EN-GJL-250	EN-JS1049, EN-GJS-400-18U-LT	GP240GH+N, 1.0619+N
1.2		Seat ring	X20Cr13+QT, 1.4021+QT	X20Cr13+QT, 1.4021+QT	≤DN65: X20Cr13+QT, 1.4021+QT ≥DN80: G19 9 NbSi, 1.4551
2		Bonnet	EN-JS1049, EN-GJS-400-18U-LT	EN-JS1049, EN-GJS-400-18U-LT	GP240GH+N, 1.0619+N
3	x	Plug	≤DN200: X20Cr13+QT, 1.4021+QT (hardened) / >DN200: P265GH, 1.0425 / Stellite 21		
4		Spindle unit			
4.1	x	Bellows seal	X6CrNiMoTi17 12 2, 1.4571		
4.2		Stem	X20Cr13+QT, 1.4021+QT		
5	x	Handwheel	≤DN125: St (cataphoretic coating) / ≥DN150: EN-JL1040, EN-GJL-250 (epoxy-coating)		
6		Packing ring	Pure graphite		
7		Hexagon bolt	5.6	--	
7		Stud	--	25CrMo4, 1.7218	
8		Hexagon nut	--	C35E, 1.1181	
9	x	Gasket	Pure graphite (CrNi laminated with graphite)		
		L Spare parts			

DN	15	20	25	32	40	50	65	80	100	125	150	200	250	300
----	----	----	----	----	----	----	----	----	-----	-----	-----	-----	-----	-----

Face-to-face dimension CTF series 8 acc. to DIN EN 558															
l	(mm)	90	95	100	105	115	125	145	155	175	200	225	275	325	375

Dimensions		Standard-flange dimensions refer to page 14														
øC	H3	(mm)	190	190	195	195	210	210	220	235	325	345	370	485	615	665
	PN16	(mm)	125	125	125	125	150	150	175	175	225	300	400	520	520	520
	PN25	(mm)	125	125	125	125	150	150	175	175	300	300	400	520	520	520
	PN40	(mm)	125	125	125	125	150	150	175	225	300	300	400	520	--	--
Travel	(mm)	6	6	8	8	13	13	16	20	25	32	40	50	70	80	
Kvs-value	(m³/h)	6	9	14	19	35	53	94	143	245	390	590	845	1360	1825	
Zeta-value	--	2,2	3,2	3,2	4,6	3,3	3,6	3,2	3,2	2,7	2,6	2,3	3,6	3,4	3,9	

Zeta-value ... range of tolerance for Kvs-values acc. to VDI/VDE 2173

Weights															
12. / 22.047	(kg)	3,7	4,4	5,1	6,5	8,3	11,2	14,6	19,4	29,4	44	58	145	221	298
34.047	(kg)	--	--	--	--	--	--	--	--	--	--	--	155	273	309
35.047	(kg)	4,6	6,4	6,7	7,5	10,1	12,7	17,5	22	34	49	60	--	--	--

Information / restriction of technical rules need to be observed!

Operating and installation instructions can be downloaded at [www.ari-armaturen.com](http://www.ari-armaturen.com).

ARI-Valves of EN-JL1040 are not allowed to be operated in systems acc. to TRD 110.

A production allowance acc. to TRB 801 No. 45 exists (acc. to TRB 801 No. 45 EN-JL1040 is not allowed.)

The engineer, designing a system or a plant, is responsible for the selection of the correct valve.

Resistance and fitness must be verified (contact manufacturer for information, refer to Product overview and Resistance list).

L = Face-to-face dimension  
 Edge shaping acc. to DIN EN ISO 5817

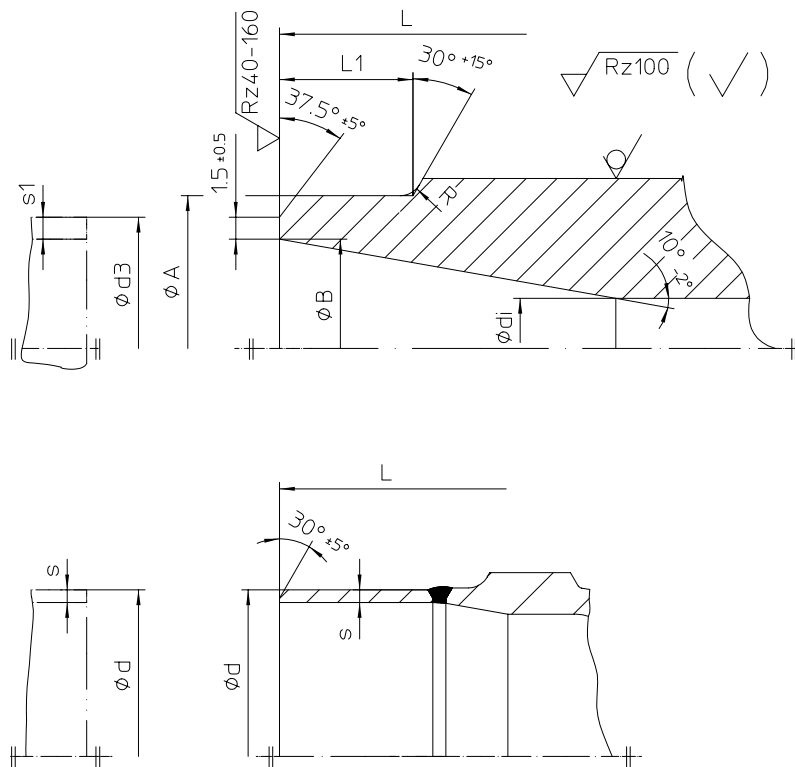

DN	15	20	25	32	40	50	65	80	100	125	150	200	250	300	350	400
----	----	----	----	----	----	----	----	----	-----	-----	-----	-----	-----	-----	-----	-----

Butt weld ends according to DIN EN 12627																	
L	(mm)	130	150	160	180	200	230	290	310	350	400	480	600	730	850	980	1100
ØA	(mm)	22	28	35	44	50	62	77	91	117	144	172	223	278	329	362	413
ØB	(mm)	17,3	22,3	28,5	37,2	43,1	53,9	68,9	80,9	104,3	130,7	157,1	204,9	257,	307,9	338,	384,4
Ødi	(mm)	15	20	25	32	40	50	65	80	100	125	150	200	250	300	330	375
R	(mm)	3	3	3	3	3	3	3	3	3	3	3	5	5	5	5	5
L1 (similar)	(mm)	10	10	10	10	10	10	10	12	14	18	20	20	25	33	45	45
Ød3	(mm)	21,3	26,9	33,7	42,4	48,3	60,3	76,1	88,9	114,3	139,7	168,3	219,1	273	323,9	355,6	406,4
s1	(mm)	2	2,3	2,6	2,6	2,6	3,2	3,6	4	5	4,5	5,6	7,1	8	8	8,8	11

Face-to-face dimension ETE series 1 according to DIN EN 12982

Butt weld ends according to DIN EN 12627 Fig. 4

Weld joint according to DIN EN 29692 code number 1.3.3

The material used for ARI valves with butt weld ends are: GP240GH+N, 1.0619+N acc. to DIN EN 10213-2,  
 P250GH, 1.0460 acc. to DIN EN 10222-2,  
 GX5CrNiMoN19-11-2, 1.4581 acc. to DIN EN 10213-4.

DN	15	20	25	32	40	50	65	80	100	125	150	200	250	300	350	400
----	----	----	----	----	----	----	----	----	-----	-----	-----	-----	-----	-----	-----	-----

Shoed ends of P235GH (Pipe connection $\Delta$ welding neck flanges)																	
Ød	(mm)	--	--	--	--	--	--	76,1	88,9	114,3	139,7	168,3	219,1	--	--	--	--
Øs	(mm)	--	--	--	--	--	--	2,9	3,2	3,6	4	4,5	6,3	--	--	--	--

The material used for ARI valves with shoed ends (DN 65-200) P235GH according to DIN EN 10216-2.

Based on our experience we recommend electric welding process for connecting valves or strainers with tubes or with each other

Lime based electrodes with an appropriate composite material should be used as filler material for welding.

Gas welding should be avoided.

Due to the different material composition and material thickness of valves and tubes, gas welding is more susceptible to produce faults than electric welding (hardness cracks, coarse-grained structure).

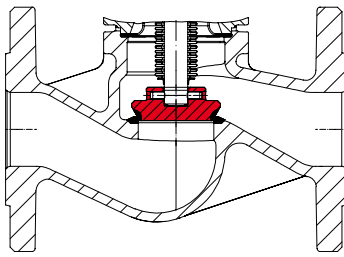

Isolation plug with marginal seat; stellited seat and plug <sup>1)</sup>

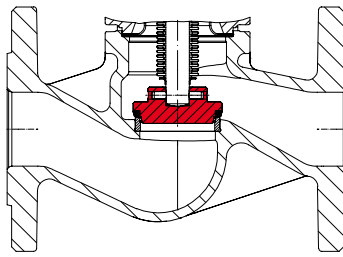

Plug with Soft seal  
Max. operating temperature 200°C  
at PTFE + 25% carbon

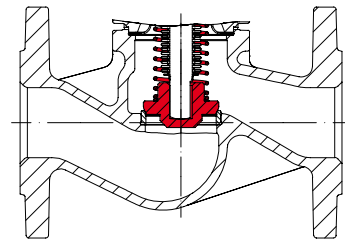

Screw down non-return plug with re-setting spring  
(Set pressure refer to annex: Flow diagram)

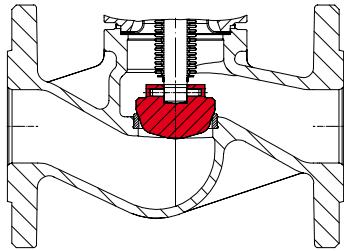

Regulating plug with marginal seat <sup>1)</sup>

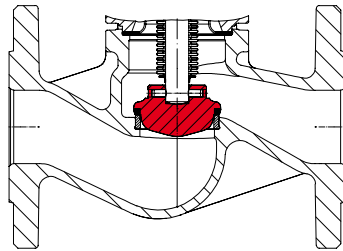

Regulating plug with soft seal <sup>1)</sup>  
Max. operating temperature 200°C  
at PTFE + 25% carbon

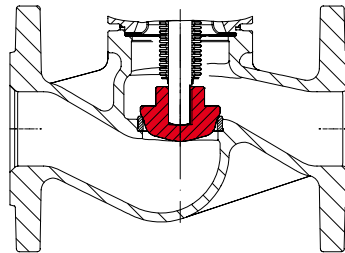

Screw down non-return regulating plug  
with marginal seat <sup>1)</sup>  
(Set pressure refer to annex: Flow diagram)

<sup>1)</sup> for max. permissible  $\Delta P$  in throttling function, refer to annex: Flow diagram

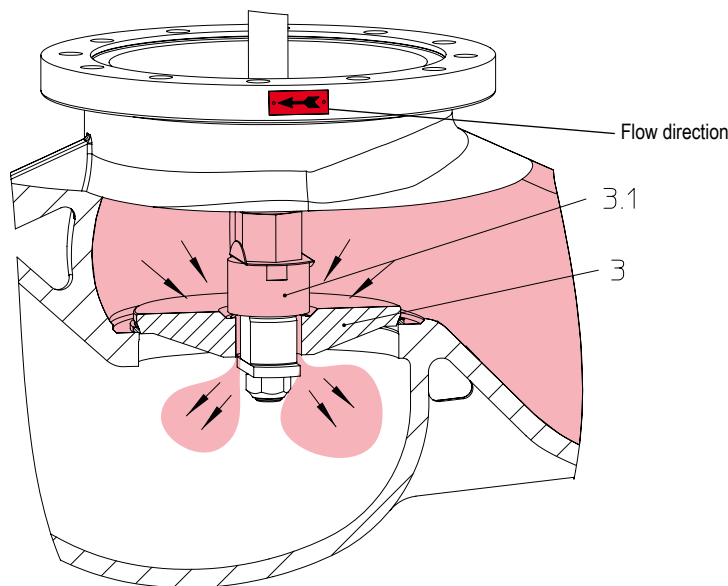

Balancing plug  
(Standard: DN15 - 300 with marginal seat, from DN350 with flat seat)

Valves with balancing plugs have to be installed with medium flowing over the plug (3) as indicated by flow direction arrow on valve body.

Working principles:

When the valve is closed, anticlockwise rotation of the hand wheel lifts the pilot plug (3.1) off the larger balancing plug (3).

This allows the medium to pass through the plug and equalizes the pressure of the medium under the plug (3). After the pressures have been equalized within the values stated in the table, the valve can be opened by turning the valve further with normal manual force.

Balancing plugs are fully effective only in closed systems.

The pressures of the medium on either side of the plug can not be equalized if the medium is discharged into open air.

A bypass line or some other arrangement is necessary if too much time is required for pressure equalization owing to the volume in the piping system.

**ARI-stop valves with differential pressures exceeding the following pressures, have to be fitted with pressure balancing plugs**

DN	125	150	200	250	300	350	400	500
Gauge press. ( $\Delta P$ ) (bar)	25	21	14	9	6	4,5	3,5	1,5

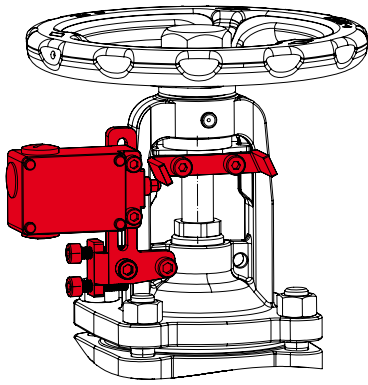

Limit switch

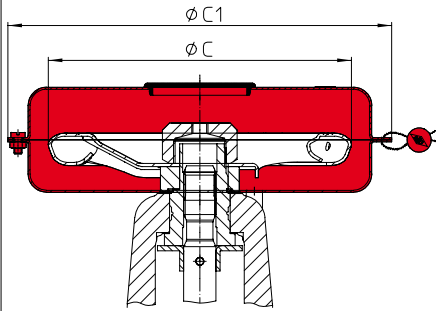

Hood valve acc. to DIN EN 12828  
(tamper resistant handwheel cover)

Size	DN (mm)	ØC (mm)	ØC1 (mm)
I	15-50	125	170
II	65-80	150	190
III	100-150	225	330

Handwheel-Ø from DN 65 reduced!

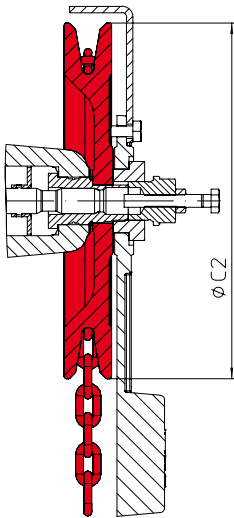

Chain wheel

DN (mm)	ØC2 (mm)	Weight (kg)
15-32	180	2,5
40-80	220	7
100-150	260	8,9
200-400	300	11

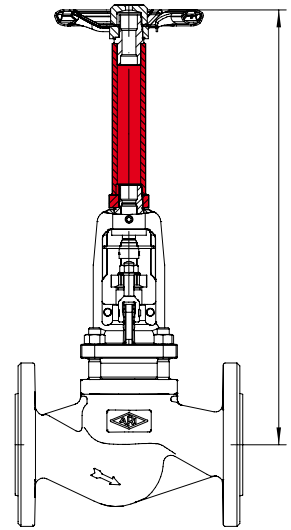

Stem extension (please specify height in your order)

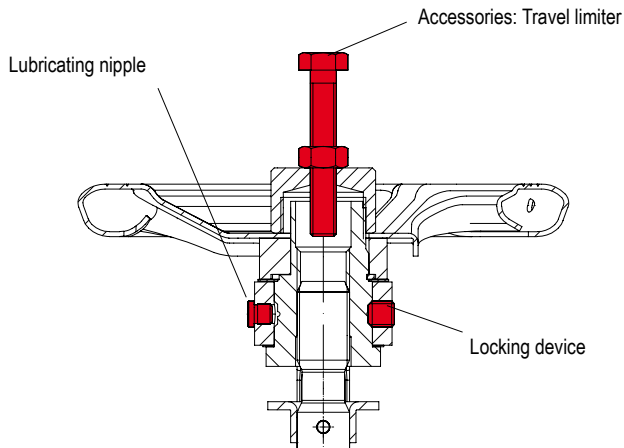

Lubricating nipple / Locking device / Travel limiter

Travel limiter  
(Accessories are not included !)

DN (mm)	Hexagon bolt (mm x mm)
15-80	M8 x 55
100	M12 x 70
125-150	M12 x 80
200	M12 x 100
250-300	M12 x 120
350-400	M16 x 160

DN	15	20	25	32	40	50	65	80	100	125	150	200	250	300	350	400	500																				
<b>Standard-flange dimensions acc. to DIN EN 1092-1/-2</b>																			Flange holes / -thickness tol. acc. to DIN 2533/2544/2545																		
PN6	ØD	(mm)	80	90	100	120	130	140	160	190	210	240	265	320	--	--	--	--																			
	ØK	(mm)	55	65	75	90	100	110	130	150	170	200	225	280	--	--	--	--																			
	n x Ød	(mm)	4x11	4x11	4x11	4x14	4x14	4x14	4x14	4x18	4x18	8x18	8x18	8x18	--	--	--	--																			
PN16	ØD	(mm)	95	105	115	140	150	165	185	200	220	250	285	340	405	460	520	580	715																		
	ØK	(mm)	65	75	85	100	110	125	145	160	180	210	240	295	355	410	470	525	650																		
	n x Ød	(mm)	4x14	4x14	4x14	4x18	4x18	4x18	4x18 <sup>1)</sup>	8x18	8x18	8x18	8x22	12x22	12x26	12x26	16x26	16x30	20x33																		
PN25	ØD	(mm)	95	105	115	140	150	165	185	200	235	270	300	360	425	485	555	620	730																		
	ØK	(mm)	65	75	85	100	110	125	145	160	190	220	250	310	370	430	490	550	660																		
	n x Ød	(mm)	4x14	4x14	4x14	4x18	4x18	4x18	8x18	8x18	8x22	8x26	8x26	12x26	12x30	16x30	16x33	16x36	20x36																		
PN40	ØD	(mm)	95	105	115	140	150	165	185	200	235	270	300	375	450	515	580	660	755																		
	ØK	(mm)	65	75	85	100	110	125	145	160	190	220	250	320	385	450	510	585	670																		
	n x Ød	(mm)	4x14	4x14	4x14	4x18	4x18	4x18	8x18	8x18	8x22	8x26	8x26	12x30	12x33	16x33	16x36	16x39	20x42																		

<sup>1)</sup> also with 8 bore holes acc. to DIN EN 1092-1/-2 possible.

<b>Pressure-temperature-ratings</b>	Intermediate values for max. permissible operational pressures can be determined by linear interpolation of the given temperature / pressure chart.
-------------------------------------	---

acc. to DIN EN 1092-2			-60°C to <-10°C <sup>1)</sup>	-10°C to 120°C	150°C	200°C	250°C	300°C	350°C	400°C	450°C
EN-JL1040	16	(bar)	--	16	14,4	12,8	11,2	9,6	--	--	--
EN-JS1049	16	(bar)	on request	16	15,5	14,7	13,9	12,8	11,2	--	--
EN-JS1049	25	(bar)	on request	25	24,3	23	21,8	20	17,5	--	--
EN-JS1049	40	(bar)	on request	40	38,8	36,8	34,8	32	28	--	--

acc. to manufacturers standard			-60°C to <-10°C <sup>1)</sup>	-10°C to 120°C	150°C	200°C	250°C	300°C	350°C	400°C	450°C
1.0619+N	25	(bar)	18,7	25	23,9	22	20	17,2	16	14,8	8,2
1.0619+N	40	(bar)	30	40	38,1	35	32	28	25,7	23,8	13,1
1.0460	25	(bar)	18,7	25	23,9	22	20	17,2	16	14,8	10
1.0460	40	(bar)	30	40	38,1	35	32	28	25,7	23,8	16

acc. to DIN EN 1092-1			-60°C to <-10°C <sup>1)</sup>	-10°C to 100°C	150°C	200°C	250°C	300°C	350°C	400°C	450°C
1.4408	16	(bar)	16	16	14,5	13,4	12,7	11,8	11,4	10,9	--
1.4408	25	(bar)	25	25	22,7	21	19,8	18,5	17,8	17,1	--
1.4408	40	(bar)	40	40	36,3	33,7	31,8	29,7	28,5	27,4	--
1.4581	16	(bar)	8	16	15,6	14,9	14,1	13,3	12,8	12,4	--
1.4581	25	(bar)	12,5	25	24,5	23,3	22,1	20,8	20,1	19,5	--
1.4581	40	(bar)	20	40	39,2	37,3	35,4	33,3	32,1	31,2	--

<sup>1)</sup> Studs and nuts made of A4-70 (at temperatures below -10°C)

**Please indicate when ordering**

- Figure-No.
- Nominal pressure
- Nominal diameter
- Special design / accessories

**Example:**

Figure 35.046; nominal pressure PN40; nominal diameter DN100.

**Technology for the Future.**  
 GERMAN QUALITY VALVES

 ARI-Armaturen Albert Richter GmbH & Co. KG, D-33750 Schloß Holte-Stukenbrock,  
 Tel. +49 52 07 / 994-0, Telefax +49 52 07 / 994-158 or 159 Internet: <http://www.ari-armaturen.com> E-mail: [info.vertrieb@ari-armaturen.com](mailto:info.vertrieb@ari-armaturen.com)